

MIDEA 20KW DUCTED SINGLE PHASE MDV-V230WN1(AU)





Midea, established in 1968 is a public company listed and since July 2016 a Fortune 500 company offering one of the most comprehensive ranges in the home appliances industry. Midea specializes in air treatment (residential and commercial solutions), refrigeration, laundry, cooking appliances, small kitchen appliances, water appliances, floor care and lighting.

Midea is My True Blue Idea

Our objective is to deliver the best home solutions for every Australia family. Our home solutions are inspired by the ideas and needs of our Australian guests. Therefore, we created the slogan "Midea is My True Blue Idea".

MD Appliances Pty Ltd

Founded in 2018 as MD Appliances Pty Ltd, we proudly represents Midea's Air conditioning products in Australia. Our mission is to bring Midea's world-class air conditioning solutions to the Australian market, ensuring that homes and commercial buildings alike benefit from cutting-edge technology, energy efficiency, and superior comfort.

more than
\$53.08B USD
of revenue in
2024

serve customers in
100+
countries

40
global production centers

190K+
employees worldwide

global Fortune
277
company



7 years parts and labor warranty

For Hi-Wall/ Ducted/ Cassette/ VRF / Heat pump



5 years parts and labor warranty

For Window Box A/C



2 years parts and labor warranty

For Heavy Commercial Products



Local after sales service and support

* Source Euromonitor International (Shanghai) Limited; Consumer Appliances 23ed, retail volume sales in unit, 2022 data

All Flare* Connections, The Easiest VRF to Install

The system uses all flare connection which can greatly simplify installation.

A single outdoor unit supports 1 indoor unit

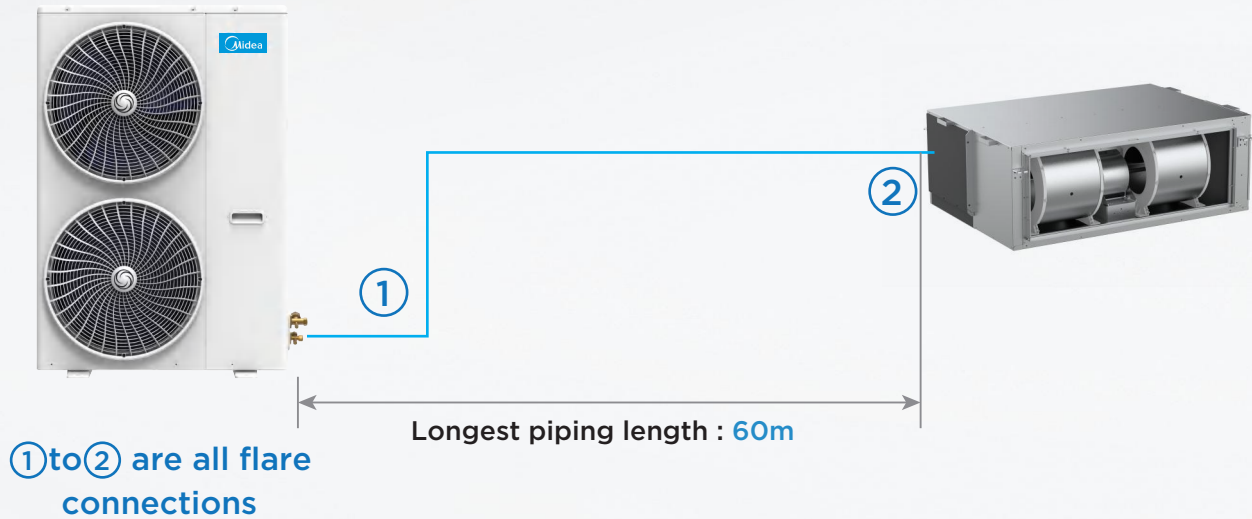

Note: Only MI2-230TIDHNI(AU) indoor unit can be connected.

Wired Controller

The WDC3-86T controller features temperature adjustment, multiple mode options, fan speed control, scheduled on/off, sleep mode, fault diagnosis, energy-saving functions, and remote control. It is designed to deliver a comfortable, energy-efficient, and convenient indoor environment control experience.

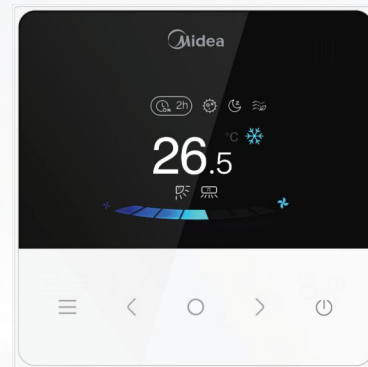

Installation of Duct in Sections

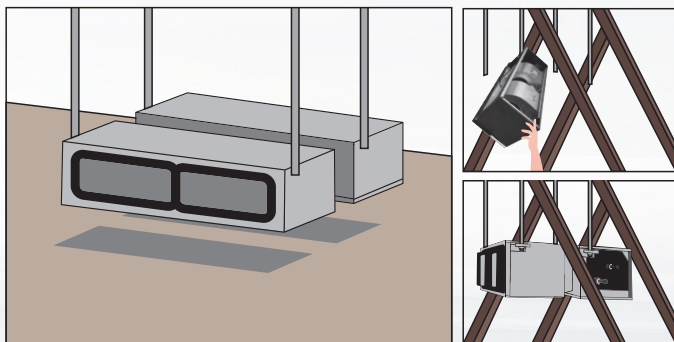

High Static Pressure Duct units support installation in sections, reducing the weight and size of individual units for easy handling and installation.

Less Required Space for Mini VRF Installation

Mini VRF use flare connections instead of welding, which facilitates owners a lot to save their cost for installation, as well as avoid health hazard by welding such as strip-lighting or extra-high temperature.



Comparing with multi split, Mini VRF has some distinctive advantages as follows:

- ◆ less pipe space requirement
- ◆ Less pipe consumption
- ◆ No special requirement for pipe holes
- ◆ keep your house neat and tidy.

Longer Piping Capability

The Mini VRF provides a total piping length possibility of 200m, a maximum height difference between outdoor and indoor units of 20m. These generous allowances facilitate an extensive array of system designs.

Piping length / Height difference		Capability (m)
Total piping length		200
1. Longest piping length	Actual	80
	Equivalent	90
2. Longest piping length after first branch		20
3. Largest level difference between IDUs and ODU	ODU up	30
	ODU down	20
4. Largest level difference between IDUs		8

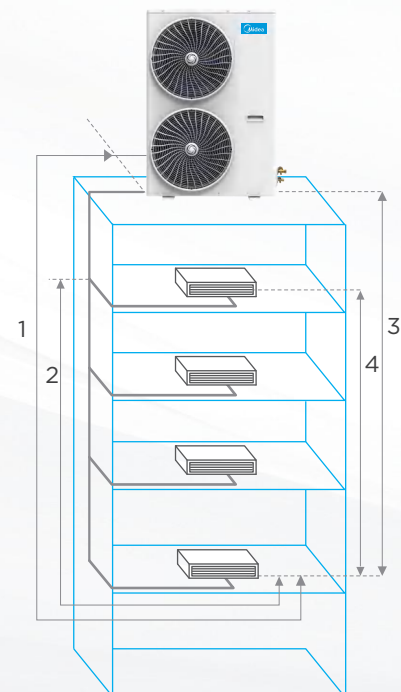

Full DC Inverter Technology

The Mini VRF uses full DC inverter compressor and fan motor to achieve high precision stepless speed adjustment according to system operation, and ensures that the system is always in optimum condition, operating more efficiently, more consistently and with less noise.

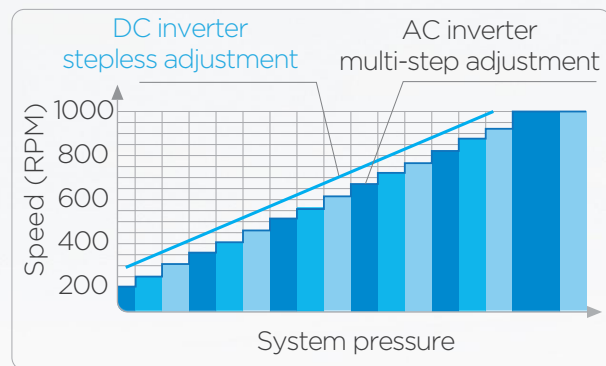
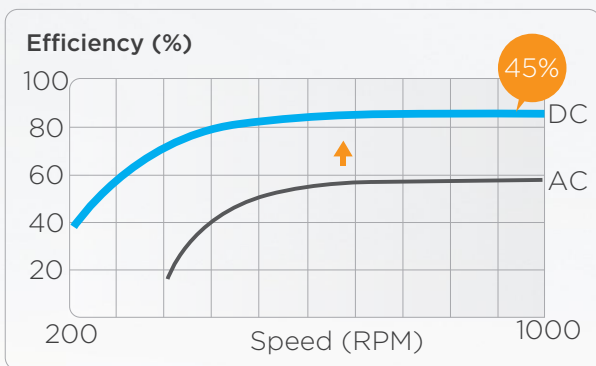

Wide Operation Range

Mini VRF can operate in a wide ambient temperature range. It can operate stably from -15°C up to 55°C in cooling mode and from -20°C to 27°C in heating mode.

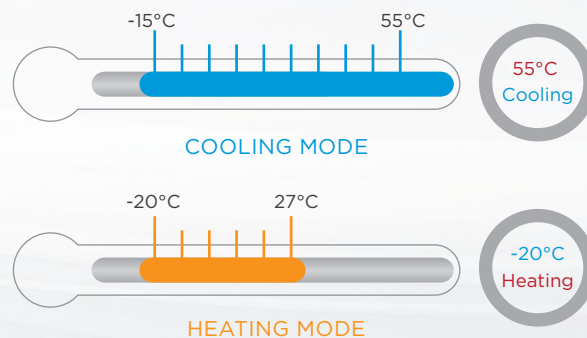

Static Pressure 20 Steps Control

Depending on the installation environment, Duct is controlled the static pressure up to 20 steps via wired remote controller, for providing comfortable environment suitable for any environment.

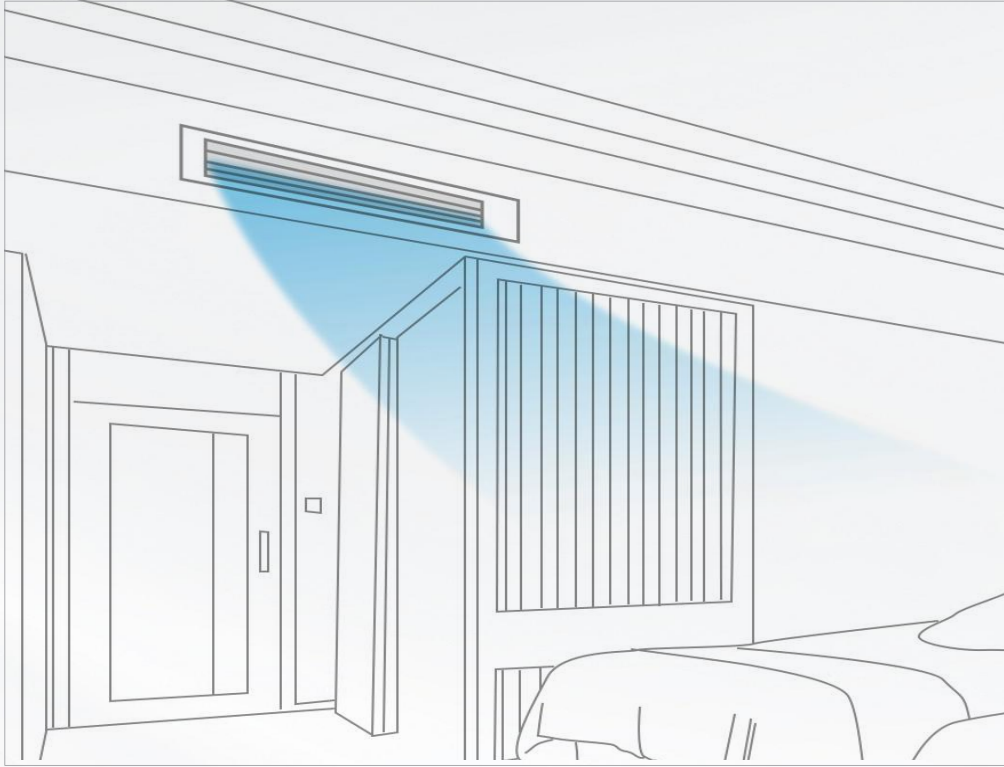

Multiple Fan Speeds

The DC Series comes with 7 indoor fan speed options to meet the needs of different indoor conditions.

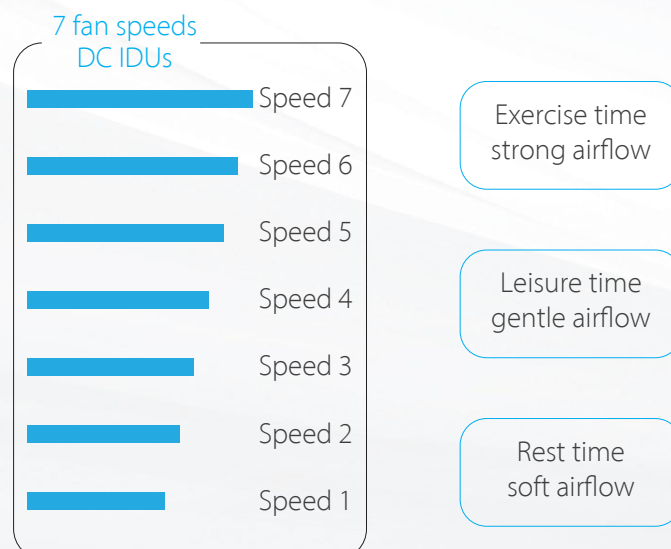

Specifications

Outdoor unit

Model			MDV-V230WN1(AU)
Power supply		V/N/Hz	220-240/1/50
Heating	Capacity	kW	23.0
	Power input	kW	5.28
Cooling	Capacity	kW	19.5
	Power input	kW	5.6
Connected indoor unit	Total capacity		60-130% of outdoor unit capacity
	Maximum quantity		12
Ambient temp. operation range	Cooling	°C	-15-55
	Heating	°C	-20-27
Sound pressure level(cooling/heating)		dB(A)	59/59
Refrigerant	Type		R410A
	Charge	Kg	4.4
pipe size	Liquid	mm	9
	Gas	mm	19
	Max. height difference	m	30(ODU up)
		m	20(ODU down)
Max. piping length	m	80	
Net dimension(W*H*D)		mm	902×1327×320
Packing dimension(W*H*D)		mm	1082×1406×434
Net/Gross weight		kg	103/111

Notes:

- Indoor temperature 20°C DB; outdoor temperature 7°C DB, 6°C WB; equivalent refrigerant piping length 7.5m with zero level difference.
- Indoor temperature 27°C DB, 19°C WB; outdoor temperature 35°C DB; equivalent refrigerant piping length 7.5m with zero level difference.
- Sound level: Anechoic chamber conversion value, measured at a point 1 m in front of the unit at a height of 1m.
During actual operation, these values are normally somewhat higher as a result of ambient conditions.
- 60-130% is system combination ratio, combination ratio=Sum of capacity indexes of the indoor units/Capacity index of the outdoor units
*The above data may be changed without notice for future improvement on quality and performance.

Indoor unit

Model			MIH200TIHN18(S)
Power supply			1-phase, 220-240V, 50/60Hz
Cooling ¹	Capacity	kW	20
	Input	W	560
Heating ²	Capacity	kW	23.5
	Input	W	560
Airflow rate ³		m ³ /h	4250/4014/3778/3542/3306/3070/2833
External static pressure ⁴		Pa	150(50-280)
Sound pressure level ⁵		dB(A)	47.5
Unit	Net dimensions ⁶ (W×H×D)	mm	1300×915×477
	Packed dimensions (W×H×D)	mm	1500×1070×640
	Net/Gross weight	kg	79.5/109
Refrigerant type			R410A/R32
Design pressure (H/L)		MPa	4.4/2.6
Pipe connections	Liquid/Gas pipe	mm	Φ9.52/Φ19
	Drain pipe	mm	ODΦ32

Notes:

- Indoor temperature 27°C DB, 19°C WB; outdoor temperature 35°C DB; equivalent refrigerant piping length 7.5m with zero level difference.
- Indoor temperature 20°C DB; outdoor temperature 7°C DB, 6°C WB; equivalent refrigerant piping length 7.5m with zero level difference.
- Fan motor speed and air flow rate are from the highest speed to the lowest speed, total 7 rates for each model.
- Stable operation external static pressure range. (Note: setting external static pressure outside the unit's optimal static pressure range may lead to higher noise levels and lower airflow rate. For the optimal external static pressure range refer to the unit's installation manual.)
- Sound pressure level is from highest level to lowest level, total 7 levels for each model. Sound pressure level is measured 1.4m below the unit in a semi-anechoic chamber.
- Unit body dimensions given are the largest external dimensions of the unit, including hanger attachments.

Victorian Energy Upgrades (VEU) Program

The Victorian Energy Upgrades (VEU) program assists households and businesses to reduce their energy bills and greenhouse gas emissions by providing financial incentives to install energy efficient equipment and appliances.

Midea has a suite of high efficiency products to suit all upgrade categories which attract the highest incentives in each program. We are proudly introducing to our range the Mini VRF series, which thanks to our labs advanced technology, are more energy efficient systems that will be further reducing carbon emissions while increasing financial savings through the incentives to the Victorian community.

For more information on the program please visit following website
VIC <https://www.esc.vic.gov.au/victorian-energy-upgrades/about-victorian-energy-upgrades-program>

VEU Climatic Region	Heating capacity(kW)	Cooling capacity(kW)	VEECs(res)**
			2025*
For upgrades in Metropolitan Victoria-Climatic region mild	23	19.5	89
For upgrades in Metropolitan Victoria-Climatic region cold	23	19.5	98
For upgrades in Regional Victoria-Climatic region mild	23	19.5	89
For upgrades in Regional Victoria-Climatic region cold	23	19.5	98
For upgrades in Regional Victoria-Climatic region hot	23	19.5	51

*All certificates have been calculated for the dates between the 1st February of that year to January 31 of the following year.

*Residential VEECS certificates have been submitted to the VEU and waiting for final approval.

**VEEC data was calculated base on activity scenatio 6 (VII)of activity 6 (23) -space heating and cooling-high efficiency air conditioner

Midea HVAC & Energy Australia

Address: 1513 Dandenong Road Oakleigh VIC 3166 Australia

Email: info@mdhome.com.au

www.mdhome.com.au

Phone: 1300 726 002

Midea HVAC & Energy Australia reserves the right to change the specifications of the product, and to withdraw or replace products without prior notification or public announcement. Midea is constantly developing and improving its products.

